







# EMERGENCY TOWING

## Arrangement for barges

### Legends:

	Towing bridle chain
	Emergency towing pennant
	Buoyant float line
	Strong point
	Emergency towing pennant leading over main bridle, connected to strong point
	Soft lashings / metal clips
	Float with self-igniting light

### Normal towing condition

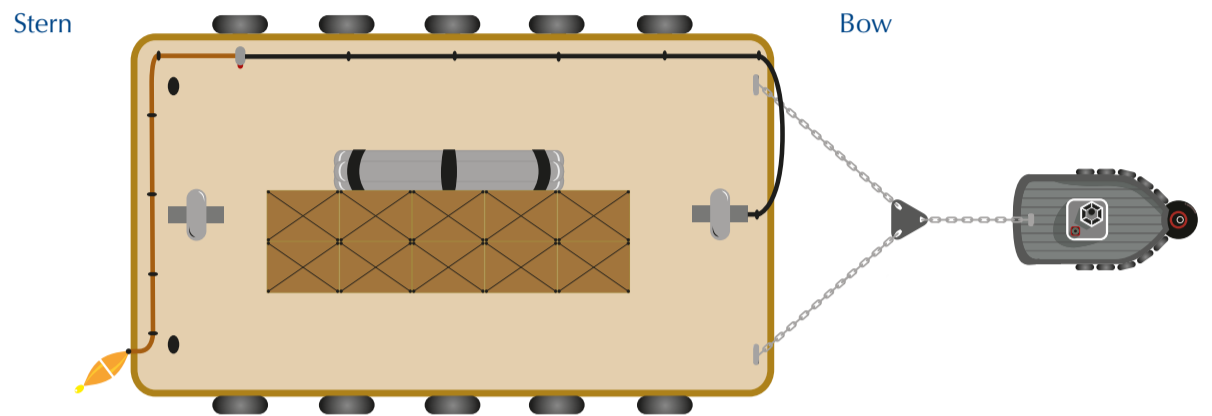

### Deployment of emergency towing gear

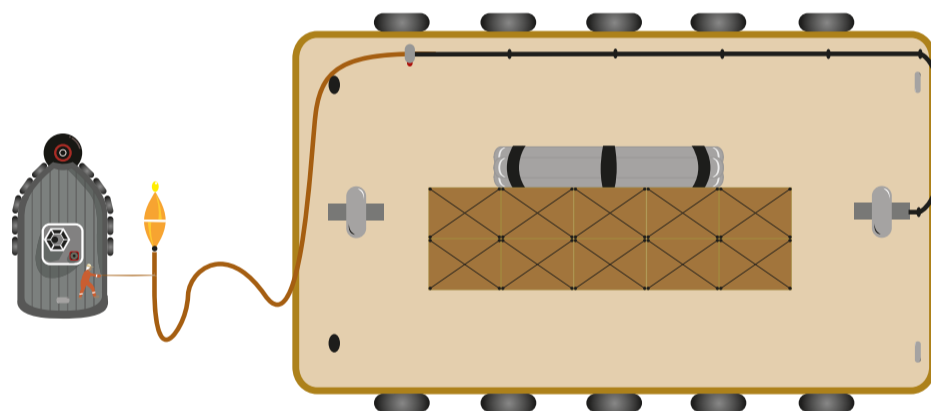

### Emergency towing gear consists of:

1. Emergency towing pennant connected to a strong point on the bow (or stern) and clear of the main bridle and other obstructions.
2. A float line connected to the emergency towing pennant and a conspicuous floating buoy with a self igniting light at the free end. The buoy is rigged at the stern so that it can easily be recovered by the tug. This must be of sufficient length to enable the buoy to float clear of the barge.
3. The pennant and the float line must be secured to the barge with soft lashings or metal clips which break free when pulled.

### Emergency towing procedures:

1. Disconnect main towing bridle from tug.
2. Manoeuvre tug to stern of barge.
3. Retrieve float line until the eye of the emergency towing pennant is onboard the tug.
4. Make fast the pennant eye to the tug towing hook.
5. Manoeuvre the tug slowly to the bow, gradually taking the weight of the tow.
6. Proceed to tow the barge to a safe location.
7. Emergency towing arrangements can also be replicated on the stern of the barge if the barge layout is suitable.

### Emergency towing

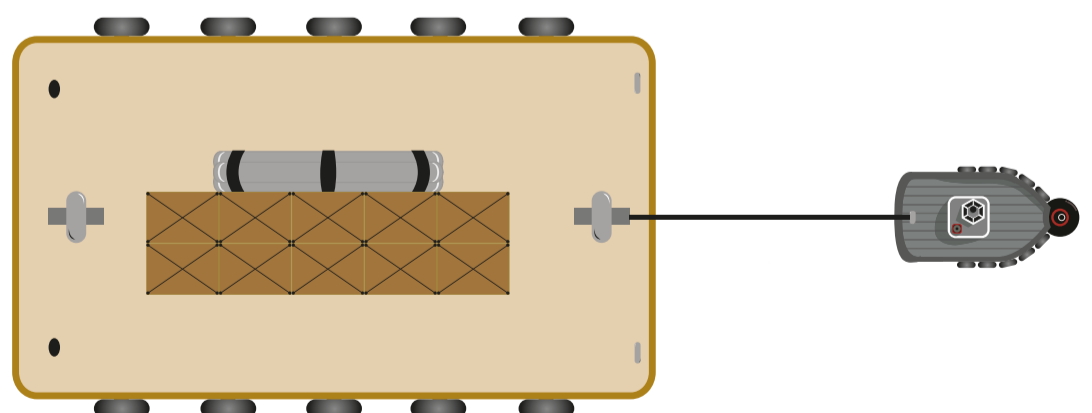

You never know when you'll need it!